



华平智慧信息技术（深圳）有限公司

Huaping Smart Information Technology (Shenzhen) Co., Ltd.

编号 No.: WCY-RD-006-04

版本(Rev): A0

型号 (Model): VICT-16KWh

16KWh 储能电源使用说明书

ESS-15.6KWh Instruction manual for energy storage
power supply

型号(Model): VICT-16KWh

电压/容量(Voltage/Capacity): 51.2V/314Ah

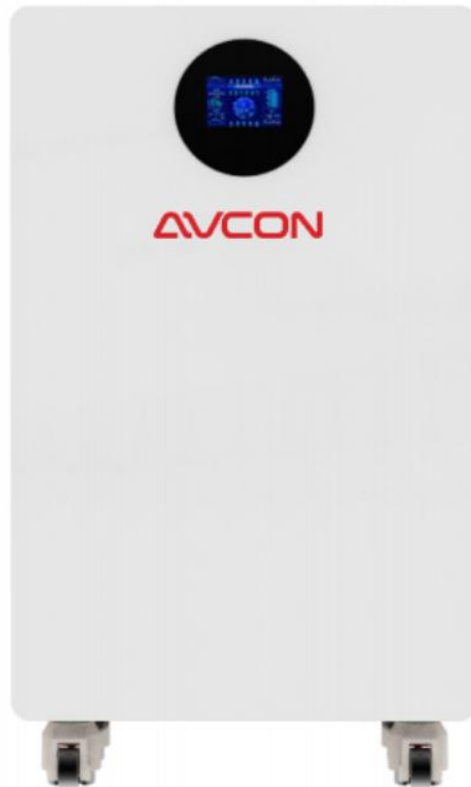

编制/日期 Prepared by/Date	审核/日期 Reviewed by/Date	批准/日期 Approved by/Date
罗肖雄 2025.06.19		



华平智慧信息技术（深圳）有限公司

Huaping Smart Information Technology (Shenzhen) Co., Ltd.

修订履历

Revision History

版本 REV.	标记 Mark	日期 Date	修订人 Reviser	修订说明 Revision Description
A0		2025-06-19	罗肖雄	First issue

目录 contents

1. 适用范围 Range of application.....	4
2. 产品特点 Product features.....	4
3. 产品电性能指标 Product Electrical Performance Index.....	7
4. 功能描述 Functional description.....	9
5. 通信说明 Communication instructions.....	13
6. 产品外观结构 Product appearance and structure.....	15
7. 电池管理系统设计 Battery management system design.....	22
8. 安装、维护注意事项 Precautions for installation and maintenance.....	23
9. 包装、运输、存储 Packaging, transportation and storage.....	24
10. 质保及其他 Warranties and others.....	24
11. 风险警告 Risk Warning.....	25

1. 适用范围 Range of application

本规格书详细描述了 VICT-15.6KWh 储能用磷酸铁锂电池系统的产品性能指标以及产品使用条件。

This specification describes in detail the product performance indicators and product use conditions of the VICT-15.6KWh lithium iron phosphate battery system for energy storage

2. 产品特点 Product features

- 落地式家储设计，美观大气，完美融入家居环境；

Floor-standing home storage design, beautiful atmosphere, perfect integration into the home environment;

- 内置高稳定 BMS，具有过充过放过流、高低温等保护功能；

Built in high stability BMS, with overcharge, discharge, overcurrent, high and low temperature protection functions;

- 最大支持 15 组并联使用，应对长时间用电环境；

Support up to 15 groups in parallel for long periods of power usage;

- 适配市场上主流品牌逆变器，为用户提供更多选择；

Adapt to mainstream brand inverters in the market to provide users with more choices;

3. 产品电性能指标 Product Electrical Performance Index

No.	项目 Items	规格 Specifications	备注 Notes
1	标称能量 Nominal energy	16KWh	标准充放电模式测试 Standard charge/discharge mode test
2	串并联方式 Series-parallel connection method	16 串 1 并	16S1P
3	标称容量 Nominal capacity	314Ah	标准充放电模式测试 Standard charge/discharge mode test
4	标称电压 Nominal voltage	51.2V	/
5	工作电压范围 Operating voltage range	40~58.4V	温度范围：-20~60℃ Temperature range: -20~60℃
6	工作温度（充电） Operating temperature (Charging)	0~55℃ ≤90%ROH	
7	工作温度（放电） Operating temperature (Discharging)	-20~60℃ ≤90%ROH	

8	标准充电 Standard charging	恒流充电: 50A Constant current charging:50A 充电 电压: 57.6V Charging voltage: 57.6V 截止电 流: 5A Cut-off current: 5A	最高单体电压 3.65V Maximum unit voltage 3.65V
9	最大充电持续电流 Maximum continuous charging current	恒流充电: 150A Constant current charging:150A 持续 电压: 57.6V Charging voltage: 57.6V 截止电 流: 5A Cut-off current: 5A	最高单体电压 3.65V Maximum unit voltage 3.65V
10	标准放电 Standard discharge	恒流放电: 100A Constant current discharge: 100A 截止电压: 40V Cut-off voltage: 40V	T≥0°C, 最低单体电压 2.5V Minimum unit voltage 2.5V
11	最大放电持续电流 Maximum continuous discharge current	恒流放电: 200A Constant current discharge: 200A 截止电压: 40V Cut-off voltage: 40V	T≥0°C, 最低单体电压 2.5V Minimum monomer voltage 2.5V
12	存储温度 Storage temperature	-20~60°C	存储环境湿度≤95%ROH, 无凝 露 Storage environment humidity ≤95%ROH, no condensation.
13	循环寿命 Cycle life	6000 @70%SOH	90% DOD, @25±2°C, 标准充放 电 模式 90% DOD, @25±2°C, standard charge and discharge mode
14	月自放电 Monthly self-discharge	≤2%/月 <2% Per month	出货三个月以后的电池, 标准充 电到 30%SOC, @25±2°C 储存 After three months' shipment, the battery will be charged to 30%SOC and stored at @ 25±2°C
15	监控通信 Communication equipment	RS485/CAN	/
16	均衡方式 Equalisation method	被动均衡 Passive equalization	/
17	出货容量 Shipping capacity	SOC 30~70% (TBD)	SOC 30~70% (TBD)
18	净量 Net weight	136.7±3Kg	
19	尺寸 Dimension	450*228*870) ±2mm	含福马轮尺寸 Including dimensions of Fuma wheels:

3.1 LED 说明 LED instructions

表 1 .LED 灯定义

Table 1. LED lamp definition

1 个开关机指示灯、1 个运行灯、1 个告警灯、6 个电量指示灯

1 switch indicator light, 1 running light, 1 alarm light, 6 power indicator light









								
L1	L2	L3	L4	L5	L6	L7	L8	L9
SOC						alarm	run	Communication

表 2.LED 工作状态指示

Table 2.LED working status indication











condition	Normal/Alarm/Protection	ON/OFF	RUN	ALM	SOC indicator LED						Description	
												
switch an electrical device off	be in sleep	off	off	off	off	off	off	off	off	off	off	All off
bide one's time	normal	On	Flash 1	off	According to the electricity indication						holding state	
	report an emergency	On	Flash 1	Flash 3							Module low voltage	
charge	normal	On	On	off	According to the electricity indication						The LED of the highest battery flashes (flash 2).	
	report an emergency	On	On	Flash 3								
	emergency			Flash 3	(The highest LED indicator flashes 2)						and ALM does not flash when the overcharge alarm is given.	
	Overcharge protection	On	On	off	On	On	On	On	On	On	On	If there is no mains supply, the indicator light turns to standby state.
	Temperature, overcurrent and failure protection	On	off	On	off	off	off	off	off	off	off	Stop charging
discharge	normal	On	Flash 3	off	According to the electricity indication							
	report an emergency	On	Flash 3	Flash 3								
	low-voltage protection	On	off	off	off	off	off	off	off	off	off	Stop discharging
	Temperature, overcurrent, short circuit, reverse connection and failure protection	On	off	On	off	off	off	off	off	off	off	Stop discharging
lose effectiveness		off	off	On	off	off	off	off	off	off	off	Stop charging and discharging

表 3.容量指示说明

Table 3. Capacity indication description

condition		charge						discharge					
Capacity indicator		L6 ●	L5 ●	L4 ●	L3 ●	L2 ●	L1 ●	L6 ●	L 5 ●	L4 ●	L 3 ●	L2 ●	L1 ●
Electri city (%)	0%~ 8%	Flash 2	off	off	off	off	off	On	off	off	off	off	off
	8%~ 26%	On	Flash 2	off	off	off	off	On	On	off	off	off	off
	26% ~ 50%	On	On	Flas h 2	off	off	off	On	On	On	off	off	off
	50% ~ 74%	On	On	On	Fla sh 2	off	off	On	On	On	On	off	off
	74% ~ 92%	On	On	On	On	Flas h 2	off	On	On	On	On	On	off
	92% ~ 100 %	On	On	On	On	On	Flash 2	On	On	On	On	On	On
Running indicator ●	On						Flashing (flashing 3)						

表 4. LED 闪动说明

Table 4. Description of the LED flashing

flash mode	bright	go out
flash 1	0.25S	3.75S
flash 2	0.5S	0.5S
flash 3	0.5S	1.5S

备注 **remarks:**

可通过上位机使能或禁止 LED 指示灯告警，出厂默认为使能的。

Can be enabled through the upper machine or prohibit LED indicator light alarm, factory default is enabled.

4. 功能描述 Functional description

4.1 待机状态 Standby state

BMS 正确连接上电后，在没有过压、欠压、过流、短路、高温、低温等保护状态下，BMS 处于待机状态。

BMS 待机状态下，运行灯闪烁，电池可进行充电和放电。

After the BMS is correctly connected to the power system, without overvoltage, undervoltage, overcurrent, short circuit, high temperature and low temperature, The BMS is in the standby state.

In BMS standby state, the running light flashes and the battery can be charged and discharged.

4.2 过充保护和恢复 Overcharge protection and recovery

4.2.1 单体过充保护和恢复 Individual overcharge protection and recovery

当电池电芯任意一节高于单体过充保护设定值时，BMS 进入过充保护状态，充电设备不能给电池充电。单体过压保护后，当最高单体电压降到单体过充恢复值以下时，解除过充保护状态。也可以放电解除。When any section of the battery cell is higher than the set value of single overcharge protection, the BMS enters the overcharge protection state, and the charging device cannot charge the battery. After monomer overvoltage protection, when the highest monomer voltage drops below the monomer overcharge recovery value, the overcharge protection state is relieved.

It can also be discharged.

4.2.2 总压过充保护和恢复 Protection and recovery of total pressure overcharge

当电池电压高于总压过充保护设定值时，BMS 进入过充保护状态，充电设备不能给电池充电。当总压电压降到总压过充恢复值以下时解除过充保护状态。也可以放电解除。When the battery voltage is higher than the total pressure overcharge protection set point, the BMS enters the overcharge protection state, and the charging device cannot charge the battery. When the overcharge protection state is removed when the total voltage drops below the total voltage overcharge recovery value. It can also be discharged.

4.3 过放保护和恢复 Protection and recovery of excessive release

4.3.1 单体过放保护和恢复 Protection and recovery of monomer overrelease

当电池电芯任意一节低于单体过放保护设定值时，BMS 进入过放保护状态，电池不能放电。30 秒后自动休眠发生过放保护后，对电池组充电可解除过放保护状态。When any section of the battery cell is lower than the single overdischarge protection set point, the BMS enters the overdischarge protection state, and the battery cannot discharge. After 30 seconds of automatic hibernation protection, the battery pack can remove the protection state.

4.3.2 总压过放保护和恢复 Protection and restoration of total pressure overdischarge

当电池电压低于总压过放保护设定值时，BMS 进入过放保护状态，电池不能继续放电。30 秒后自动休眠发生过放保护后，对电池组充电可解除过放保护状态。When the battery voltage is lower than the total voltage overdischarge protection setting value, the BMS enters the overdischarge protection state, and the battery cannot continue to discharge. After 30 seconds of automatic hibernation protection, the battery pack can remove the protection state.

4.4 充电过流保护和恢复 Charging overcurrent protection and recovery

当充电电流超过充电过流保护设置值时，且达到延时时间。BMS 进入充电过流保护，充电设备不能给电池充电。发生充电过流保护后，BMS 自动延时恢复，放电也可以解除充电过流保护。充电过流保护发生次数达到条件会锁定，放电解除。When the charging current exceeds the set value of the charging overcurrent protection, and the delay time is reached. The BMS enters the charge overcurrent protection, and the charging device cannot charge the battery. After the charging overcurrent protection occurs, the BMS will automatically delay the recovery, and the discharge can also remove the charging overcurrent protection. The occurrence times of charging overcurrent protection will reach the condition and lock, and the discharge will be lifted.

4.5 放电过流保护和恢复 Discharge and overcurrent protection and recovery

当放电电流超过放电过流保护设置值时，且达到延时时间。BMS 进入放电过流保护，电池不能放电。发生放电过流保护后，BMS 自动延时恢复，充电也可以解除放电过流保护发生次数达到条件会锁定，充电解除。When the discharge current exceeds the discharge overcurrent protection setting value, and the delay time is reached. BMS into the discharge of overcurrent protection, the battery can not discharge. After the discharge overload protection occurs, BMS automatically delay recovery, and the charging can also remove the discharge overload protection when the conditions are locked, and the charging is lifted.

4.6 温度保护和恢复 Temperature protection and recovery

BMS 有 6 个温度检测端口，实行监测温度变化达到保护措施。BMS has 6 temperature detection ports, and implement monitoring temperature changes to achieve protection measures.

4.6.1 充放电高温保护和恢复 High-temperature protection and recovery of charge and discharge

当充放电状态下，4 个电芯 NTC 随意一个高于高温保护设定值时，BMS 进入高温保护。BMS 停止充电或者放电。

当电芯温度低于高温恢复值时，BMS 恢复充电或者放电。 In the charge and discharge state, when one of the 4 cells NTC is arbitrarily higher than the high temperature protection set point, the BMS enters the high temperature protection. The BMS stops charging or discharging. When the temperature of the cell is lower than the high temperature recovery value, the BMS resumes charging or discharging.

4.6.2. 充放电低温保护和恢复 Low-temperature protection and recovery of charge and discharge

当充放电状态下，4 个电芯 NTC 任意一个低于低温保护设定值时，BMS 进入低温保护。BMS 停止充电或者放电。当电芯温度高于低温恢复值时，BMS 恢复充电或者放电。 When any of the four cell NTC under charge and discharge is below the cryogenic protection set point, BMS enters the cryogenic protection. The BMS stops charging or discharging. When the cell temperature is higher than the low temperature recovery value, the BMS resumes the charge or discharge.

4.6.3. 环境温度保护、MOS 温度保护 Environmental temperature protection and MOS temperature protection

当 NTC 检测到环境温度高于环境高温设定值时，BMS 进入环境高温保护。BMS 停止充放电。当 NTC 检测到 MOS 温度高于功率保护设定值时，BMS 进入 MOS 高温保护。BMS 停止充放电。 When the NTC detects that the ambient temperature is higher than the ambient high temperature set point, the BMS enters the ambient high temperature protection. The BMS stops charging and discharging. When the NTC detects the MOS temperature above the power protection setting, the BMS enters the MOS high temperature protection. The BMS stops charging and discharging.

BMS 具有充电均衡功能，BMS 系统采用能量消耗型均衡电路，均衡开启电压上位机可设置，均衡开启条件任意一节高于均衡开启电压并且压差大于设定值。当停止充电或者电芯压差小于设定值时关闭。

4.7 均衡功能 Balanced function

BMS 具有充电均衡功能，BMS 系统采用能量消耗型均衡电路，均衡开启电压上位机可设置，均衡开启条件任意一节高于均衡开启电压并且压差大于设定值。当停止充电或者电芯压差小于设定值时关闭。 BMS has the function of charging balancing. BMS, BMS system adopts the energy consumption equalization circuit, the equilibrium open voltage upper machine can be set, any section of the equilibrium opening condition is higher than the equilibrium open voltage and the voltage difference is greater than the set value. Turn off when the charging is stopped or the cell pressure difference is less than the set value.

4.8 休眠、待机、关机 sleep, standby, shutdown

order number	function	definition
1	Sleep to standby	When the BMS is in sleep mode, press the reset button for 3-6 seconds, and the LED indicator lights will light up sequentially before entering standby mode.
2	Switch from standby to sleep	When the BMS is in standby mode, press the reset button for 3-6 seconds, and the LED indicator lights will turn off one by one before entering sleep mode.
3	Shutdown	External switches can control the BMS on/off, with the highest priority given to external switches

5. 通信说明 Communication instructions

5.1 外部 CAN 通信 External CAN communication

BMS 具备电池组上传 CAN 通信功能(地址 1, 波特率 500K)。CAN 通信接口采用 8P8C 网线接口, 通过 CAN 接口可跟逆变器通信。电池组集联时, 通过内部 RS485 通信集联, 最后通过 CAN 通信把电池组数据、状态、信息进行上传 PCS。 BMS has the battery pack upload CAN communication function (address 1, port rate 500K). The CAN communication interface adopts 8P8C network cable interface, which can communicate with the inverter through the CAN interface. When the battery pack is connected, through the internal RS485 communication cluster connection, and finally the battery pack data, status and information are uploaded to PCS through CAN communication.



CAN 通信接口定义: CAN communication interface definition:

pin	Definition description	Port description	Top view
1	RS485-B1	PCS interface	
2	RS485-A1		
3	Communication SGND		
4	CANH		
5	CANL		

5.2 外部 RS485 通信 External RS485 communication

BMS 具备电池组上传 RS485 通信功能(地址 1, 波特率 9600bps)。RS485 通信接口采用 8P8C 网线接口。通过外部 RS485 接口可跟逆变器通信。电池组集联时, 通过内部 RS485 通信集联, 最后通过外部 RS485 通信把电池组数据、状态、信息进行上传 PCS。 BMS has the battery pack upload RS485 communication function (address 1, port rate 9600bps). RS485 The communication interface adopts 8P8C network cable interface. It can communicate with the inverter through the external RS485 interface. When the battery pack is connected, the internal RS485 communication is connected, and finally the battery pack data, status and information are uploaded to PCS through the external RS485 communication. 外

部 RS485 通信接口定义: External RS485 communication interface definition:

pin	Definition description	Port description	Top view
1	RS485-B2	Parallel Interface	
2	RS485-A2		
3、6	Communication		
	SGND		
4	CANL		
5	CANH		
7	RS485-A1		
8	RS485-B1		
1	RS485-B2	Parallel interface OUT	
2	RS485-A2		
3、6	SGND		
4	CANL		
5	CANH		
7	RS485-A1		
8	RS485-B1		

5.3 RS232 通信 RS232 communication

BMS 具备 RS232 通信功能 RS232 通信接口采用 8P8C 网线接口。通过 RS232 接口可与上位机通信。实时监控电池组数据、状态等信息。The BMS has the RS232 communication function. The RS232 communication interface adopts the 8P8C network cable interface. Communicate with the upper computer through the RS232 interface. Real-time monitoring of battery pack data, status and other information.

RS232 通信接口定义 RS232 Communication interface definition:

pin	Definition description	Port description	Top view
1	NO1	DEBUG interface	
2	COM1		
3	RS232-TX/RS485A		
4	RS232-RX/RS485B		
5	SGND		
6	NO2		
7	COM2		

5.4 并机 RS485 通信 Combined RS485 communication 多机并联时内部 RS485 接口作为

并机通信接口，外部 RS485/CAN 接口作为上联通信接口。终端设备可以通过外部 RS485/CAN 接口读取所有并联 PACK 的电池数据的总和。多机并联时，内部

The internal RS485 interface serves as the parallel communication interface, and the external RS485 / CAN interface serves as the upper connected communication interface.end

The terminal device can read the sum of the battery data of all the parallel PACK through the external RS485 / CAN interface. When the multi-machine is in parallel, the internal

RS485 接口连接见下图 RS485 Interinterface is shown in the following figure:

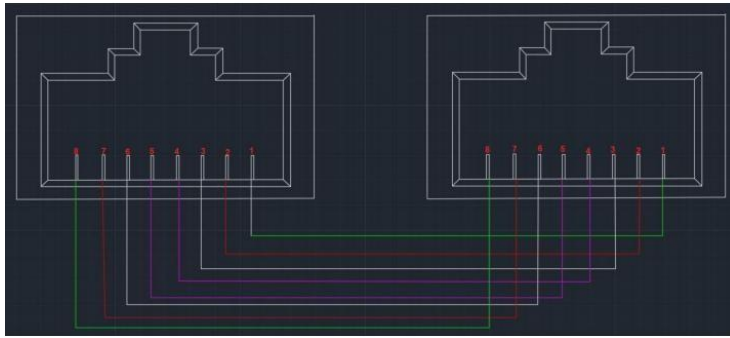

5.5 接口图示 interface diagram

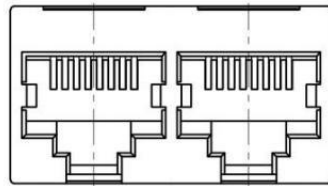

CAN 和 RS485 接口



干接点

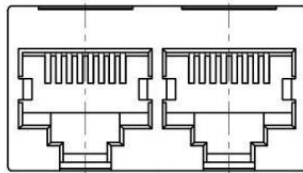

并联通讯端口

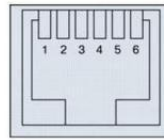

RS232 通讯接口

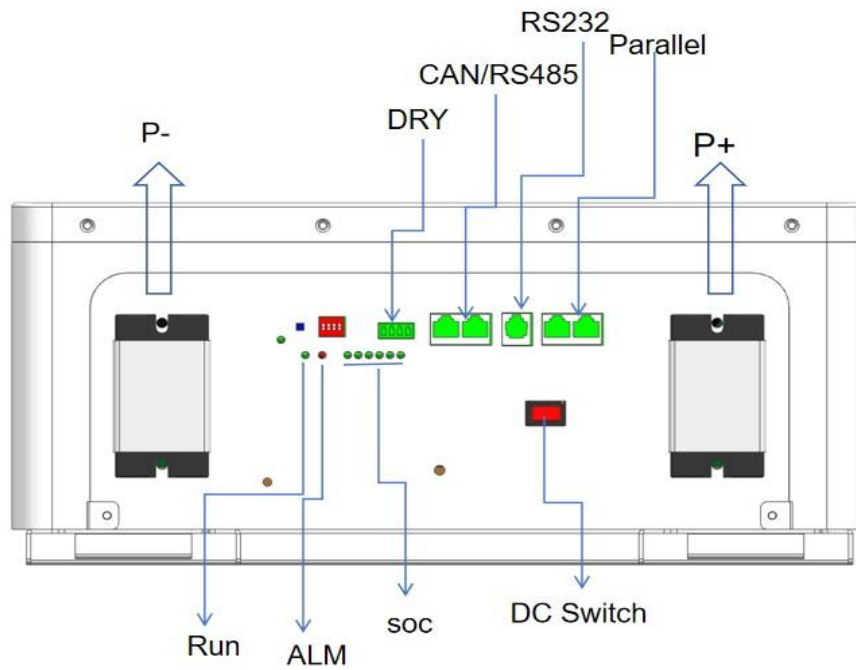

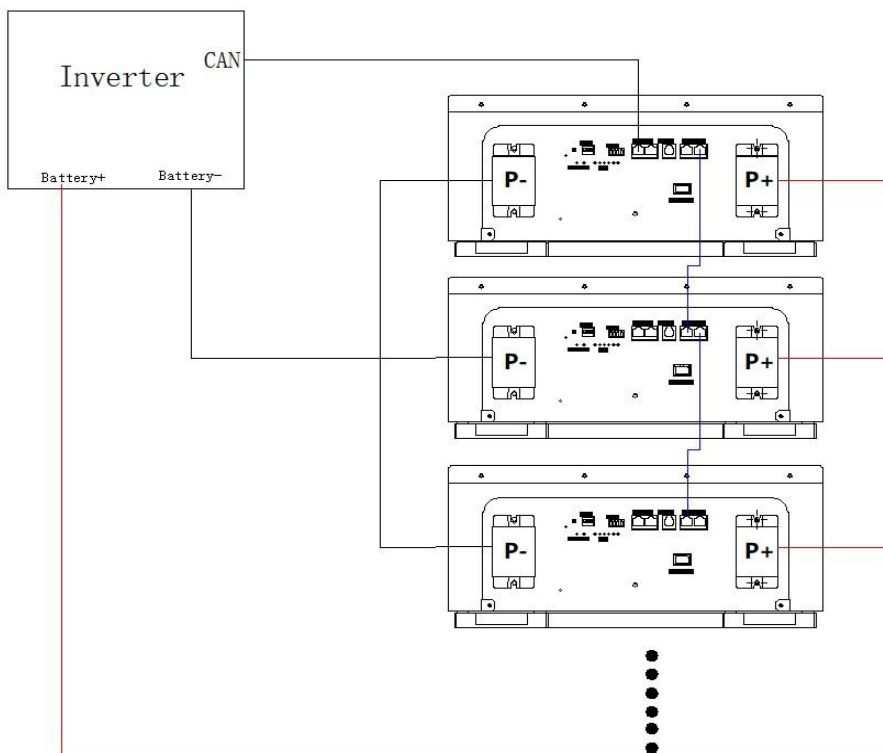

多台并机接线图
Multiple parallel machines

6. 产品外观结构 Product appearance and structure

6.1 结构尺寸 Structural dimensions

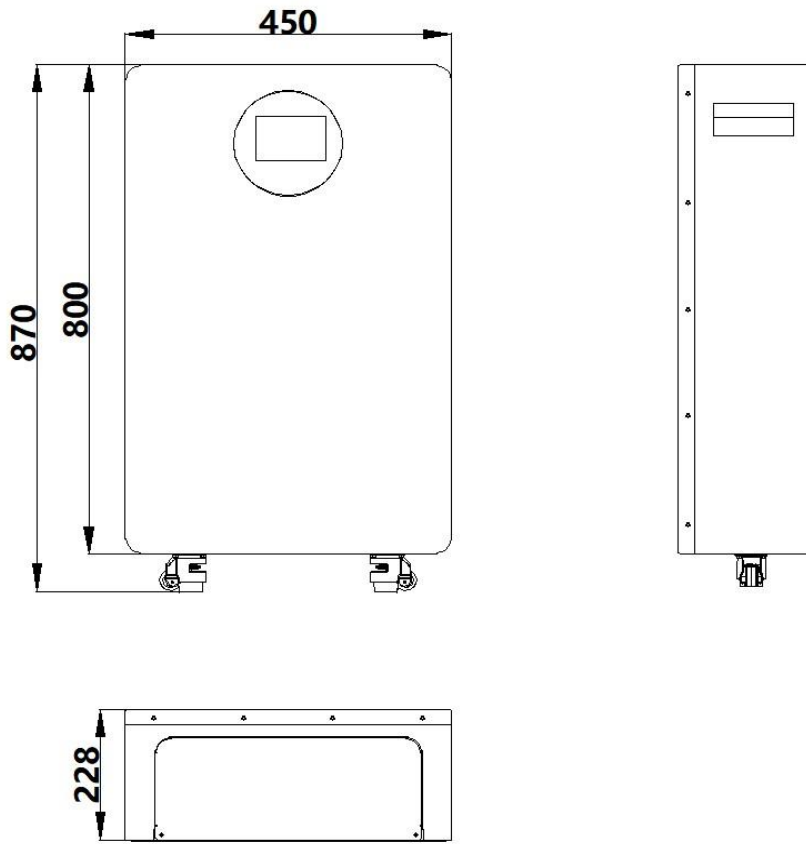

6.2 附件：配置清单 Appendix : Configuration list

品名 Name	规格 Type	数量 QTY
电池 Battery	VICT-15.6KWh	1
通讯线 Comm cable	6类千兆网非屏蔽网络线/CAT6-1.5M/RoHS	1

6.3 应用场景拓扑 Application Scenario Topology



7. 电池管理系统设计 Battery management system design

7.1 工作模式及状态 Working mode and status

7.1.1 充电模式 Charging mode

BMS 在检测到外部有充电电压且 $\geq 48V$ ，同时电芯电压及温度均在可充电范围内时，开启充电 MOSFET 进行充电。充电电流达到有效充电电流时，进入充电模式。充电模式下充、放电 MOSFET 都导通。

When the BMS detects that the external charging voltage is $\geq 48V$, and the cell voltage and temperature are within the chargeable range, the charging MOSFET is turned on for charging. When the charging current reaches the effective charging current, it will enter the charging mode. Both charging and discharging MOSFETs are on in charge mode.

7.1.2 放电模式 Discharging mode

BMS 在检测到负载连接且电芯电压及温度在可放电范围内，放电电流达到有效放电电流时进入放电模式。

The BMS enters the discharge mode when it detects that the load is connected, the cell voltage and temperature are within the dischargeable range, and the discharge current reaches the effective discharge current.

7.1.3 待机模式 standby mode

以上两种模式都不满足时，进入待机模式。

When neither of these modes is satisfied, enter standby mode.

7.1.4 休眠模式 Sleep mode

到正常待机规定时间后、电池触发欠压保护、执行按键关机或上位机执行关机命令，BMS 进入休眠（关机）模式。

The BMS enters sleep (shutdown) mode when the normal standby time is reached, the battery triggers undervoltage protection, the button is pressed to shutdown or the host computer executes a shutdown command.

休眠模式的唤醒条件：1、充电激活； 2、按键开机。

Wake up conditions of sleep mode: 1. Charging is active; 2. Press the button to start.

7.2 电气参数表 Electrical parameter table

序号 order number	指标项目 Indicator project		出厂默认参数 Factory default parameters	是否可 设 Whether can set	备注 remarks
1	单体过充保护 Single overcharge protection	单体过充告警电压 Single-unit overcharge alarm voltage	3600mV	可设 Can set	
		单体过充保护电压 Single-body overcharge protection voltage	3650mV	可设 Can set	
		单体过充保护延时 Protection time delay of monomer overcharge	1.0S	可设 Can set	
	单体过压保护 解除 The monomer overpressure protection is lifted	单体过充保护解除电压 Single-body overcharge protection and release voltage	3300mV	可设 Can set	
		容量解除 Capacity lifted	SOC<96%	可设 Can set	
		放电解除 Discharge discharge	放电电流 > 1A Discharge current o f > 1A		
2	单体过放保护 Single over- release protection	单体过放告警电压 Single unit overdischarge alarm voltage	2750mV	可设 Can set	过放保护后，仍 无法恢复时，将 进入低功耗模式 After the release protection, still unable to recover, will enter the low power mode
		单体过放保护电压 Single-unit overdischarge protection voltage	2500mV	可设 Can set	
		单体过放保护延时 Single unit overrelease protection delay	1.0S	可设 Can set	
	单体过放保护解 除 The	单体过放保护解除电压 Single body overdischarge protection and release	3100mV	可设 Can set	

	monomer overrelease protection is released	voltage			
		有充电时解除 Discharge when charged	接入充电器可激活 Access charger can be activated		
3	总体过充保护 Overall overcharge protection	总体过充告警电压 Overall overcharge alarm voltage	57.6V	可设 Can set	
		总体过充保护电压 Overall overcharge protection voltage	58.4V	可设 Can set	
		总体过充保护延时 Overall overcharge protection delay	1.0S	可设 Can set	
	总体过压保护解除 Overall overpressure protection lifted	总体过充保护解除电压 Overall overcharge protection relief voltage	52.8V	可设 Can set	
		容量解除 Capacity lifted	SOC < 96%	可设 Can set	
		放电解除 Discharge discharge	放电电流 > 1A Discharge current o f > 1A		
4	总体过放保护 Overall overrelease protectio	总体过放告警电压 Overall over alarm voltage	44V	可设 Can set	过放保护后，仍无法恢复时，将进入低功耗模式 After the release protection, still unable to recover, will enter the low power mode
		总体过放保护电压 Overall overdischarge protection voltage	40V	可设 Can set	
		总体过放保护延时 Overall overrelease protection delay	1.0S	可设 Can set	

	总体过放保护解除 The overall overdischarge protection is relieved	总体过放保护解除电压 Overall overdischarge protection release voltage	49.6V	可设置 Can set	
		有充电时解除 Discharge when charged	接入充电器可激活 Access can be activated		
5	充电限流功能 Charging limit function	充电限流电流 Charging limit current	20A		限流开启可设置，最大开启电流值 200A The current limit is open and can be set, and the maximum open current value is 200A
6	充电过流保护 Charging overcurrent protection	充电过流告警电流 Charge the overcurrent alarm current	205A	可设置 Can set	
		充电过流保护电流 Charge the overcurrent protection current	210A	可设置 Can set	
		充电过流保护延时 Charging overcurrent protection delay	1.0S	可设置 Can set	
	充电过流保护解除 Charging overcharge protection is removed	自动解除 Automatic lifting	1min 后自动解除 Automated release after 1min		
		放电解除 Discharge discharge	放电电流 > 1A Discharge current of > 1A		
6	放电过流 1 保护 Discharge overcurrent 1 protection	放电过流 1 告警电流 Discharge overcurrent 1 alarm current	205A	可设置 Can set	
		放电过流 1 保护电流 Discharge current 1 protection current	210A	可设置 Can set	
		放电过流 1 保护延时 Overcurrent discharge 1	1.0S	可设置 Can set	

		protection delay		
	放电过流 1 保护解除 Discharge overflow 1 protection is relieved	自动解除 Automatic lifting	1min 后自动解除 Automated release after 1min	
		充电解除 Charging to remove	充电电流 > 1A Charging current is > 1A	
7	放电过流 2 Discharge over current 2	放电过流 2 保护电流 Discharge overcurrent protection current 2	≥250A	可设 Can set
		放电过流 2 保护延时 Discharge current 2 protection delay	100mS	可设 Can set
	放电过流 2 保护解除 Discharge overcurrent 2 protection is relieved	自动解除 Automatic lifting	1min 后自动解除 Automated release after 1min	
		充电解除 Charging to remove	充电电流 > 1A Charging current $i_s > 1A$	
8	短路保护 short-circuit protection	短路保护功能 Short-circuit protection function	有 have	
		/		
		短路保护解除 circuit protection Short lifted	有充电时，短路保解除 护 When circuit charged, the over shor protection is removed When the load is removed	
9	MOS 高温保护 The MOS hightemperature protection	MOS 过温告警温度 MOS overtemperature alarm temperature	90°C	可设 se Can t
		MOS 过温保护温度 The MOS over-temperature protection temperature	115°C	可设 se Can t
		MOS 保护解除温度 MOS protection release temperature	85°C	可设 se Can t
10	电芯温度保护 Battery temperature	充电低温告警温度 Charging low temperature alarm	5°C	可设 se Can t

	protection	temperature		
		充电低温保护温度 Charging for the lowtemperature protection temperature	0℃	可设 Can set
		充电低温保护解除温度 Charging with low temperature	5℃	可设 Can set

		protection to the release temperature		
		充电高温告警温度 Charging high temperature alarm temperature	50℃	可设 Can set
		充电高温保护温度 Charging with high temperature protection temperature	55℃	可设 Can set
		充电高温保护解除温度 Charging with high temperature protection to release the temperature	50℃	可设 Can set
		放电低温告警温度 Discharge low-temperature alarm temperature	-15℃	可设 Can set
		放电低温保护温度 Discharge cryogenic protection temperature	-20℃	可设 Can set
		放电低温保护解除温度 Discharge is a lowtemperature protection device to release the temperature	-15℃	可设 Can set
		放电高温告警温度 Discharge high temperature alarm temperature	55℃	可设 Can set

		放电高温保护温度 Discharge at a hightemperature protection temperature	60°C	可设 Can set	
		放电高温保护解除温度 Discharge high temperature protection release temperature	55°C	可设 Can set	
11	环境温度告警 Environmental temperature alarm	环境低温告警温度 Environmental low-temperature alarm temperature	-15°C	可设 Can set	
		环境低温保护温度 Environmental low-temperature protection temperature	-20°C	可设 Can set	
		环境低温保护解除温度 Environmental low temperature protection to release the temperature	-15°C	可设 Can set	
		环境高温告警温度 Ambient high temperature alarm temperature	55°C	可设 Can set	
		环境高温保护温度 Environmental hightemperature protection temperature	65°C	可设 Can set	
		环境高温保护解除温度 Environmental high temperature protection to release the temperature	55°C	可设 Can set	
12	消耗电流 Consumption of current	工作时自耗电电流 Self-consuming current operation at	≤50mA (带显示屏 screen) with display		
			≤40mA (不带显示屏 y without a displa screen)		
		低功耗模式电流 Low-power consumption mode current	≤200μA		
13	均衡功能	均衡开启电压 age	3400mV	可设 Can set	

	Balanced function	Balanced turn on volt		Can	
		开启压差 Turn on the pressure difference	30mV	可设 Can set	
14	容量默认设置 Capacity default settings	电量低告警门槛 Power quantity is low alarm threshold for	SOC<5%	可设 Can set	充电时不告警 No alarm when charging
15	休眠功能 Sleep function	休眠电压 The dormant voltage	3150mV	可设 Can set	
		延迟时间 delay time	5min	可设 Can set	
16	电芯失效保护 Power cell failure protection	单体压差 pressure difference Single	压差>1V	不可设 Do not set	不允许充放电 Charge and discharge are not allowed
17	满充判断 Full charge judgment	满充电压 Full charge voltage	>55.5V	可设 Can set	同时满足后停止充电，并更新SOC为100%
		截止电流 off current cut	<2A	可设 Can set	

8. 安装、维护注意事项 Precautions for installation and maintenance

8.1 安装注意事项 Precautions for installation

- (1) 安装前拆箱、检测配件数量和电池外观；
Unpacking, checking the number of accessories and the appearance of the batteries before installation;
- (2) 安装壁挂支架，测量电池电压，一般电池出厂电压在 50.4V - 53.5V（电量 20%-60%）之间；
Install the wall-mounted bracket and measure the battery voltage. Generally, the factory voltage is in the range of 50.4V-53.5V (SOC 20%-60%);
- (3) 接线前查看好电池正负极，严禁在安装电池时正负极端子安装反；
Check the positive and negative terminals of the batteries before wiring. It is strictly forbidden to install the positive and negative terminals backwards when installing the batteries;
- (4) 在电池连接过程中请戴好防护手套，使用扭矩扳手等金属工具时，请将金属工具进行绝缘包装，绝对避免扭矩扳手等金属工具两端同时接触到电池正、负端子，造成电池短路；
Please wear protective gloves during battery connection. When using metal tools such as torque wrench, please pack the metal tools in insulation, so as to avoid the battery short circuit caused by both ends of metal tools such as torque wrench touching the positive and negative terminals of the battery at the same time;
- (5) 跟外接设备连接之前，使设备处于断开状态，并再次检查电池的连接极性和总电压是否正确，然后再将电池的正极连接设备的正极，电池的负极连接设备的负极端，并紧固好连接线；

Before connecting to an external device, leave the device disconnected and check again that the battery connection polarity and total voltage are correct, then connect the positive terminal of the battery to the positive terminal of the device and the negative terminal of the battery to the negative terminal of the device, and fasten the connection cable;

- (6) 电池在搬运和摆放中必须轻拿轻放，严禁坠落、冲击，禁止抛掷、敲打电池，以免损坏电池或导致安全隐患； Batteries must be handled and placed gently, no dropping, impacting, throwing and knocking, to prevent damage to the battery or cause safety hazards;
- (7) 禁止使用工具的尖锐部件接触到电池箱表面，划伤或损坏电池箱； It is forbidden to use sharp parts of tools to touch the surface of the battery box, and scratch or damage the battery box;
- (8) 禁止私自拆解电池箱；
It is forbidden to disassemble the battery box without permission.
- (9) 禁止将任何金属、导电材质物件与电池放置一起或者一起组装进电池箱；
It is forbidden to put or assemble any metal or conductive materials together with the battery box;
- (10) 安装前确保墙体符合壁挂要求；
Ensure the wall meets the wall hanging requirements before installation;

8.2 维护注意事项 Maintenance precautions

- ◆ 安装使用后期可以对电池进行简单的维护检验，如 6 个月进行一次；

Simple maintenance and inspection of the batteries can be carried out at a later stage of installation and use, e.g. once every 6 months;

- ◆ 检查电池正负极极柱、连接线是否出现松动、损伤、变形成腐蚀等现象，电池壳体有无损伤、变形；

Check the positive and negative battery poles and connecting wires for looseness, damage, corrosion, etc., and the battery case for damage and deformation;

- ◆ 如果出现故障，电池发出告警，请检查电池连接是否正确或是否存在过流情况；之后按复位按键，电池重启后看故障是否消除，如无法消除请联系厂家处理，请勿擅自打开电池组箱体；

If a fault occurs and the battery gives an alarm, please check if the battery is connected correctly or if there is an overcurrent situation, then press the reset button and check if the fault is eliminated after the battery is restarted, if it cannot be eliminated please contact the manufacturer for handling, please do not open the battery pack case without permission;

- ◆ 针对多组电池并联的应用场景，如果当中的一组电池出现故障需要替换，请确保新替换的电池组电压和需要并联的其他电池组的电压压差在 2V 以内，如果压差较大，会发生电压高的电池组给电压低的电池组大电流充电，电压低的电池组发生充电过流保护，导致无法充电；

For applications where multiple batteries are connected in parallel, if one of the batteries fails and needs to be replaced, ensure that the voltage difference between the new battery pack and the other batteries to be connected in parallel is within 2V. If the voltage difference is large, the battery pack with high voltage will charge the battery pack with low voltage at high current and the battery pack with low voltage will be over-current protected, resulting in failure to charge;

- ◆ 记录停电的时间和次数，对电池的供电时间做详细的统计；

Record the time and number of power failure, and make detailed statistics on the power supply time of the battery;

9. 包装、运输、存储 Packaging, transportation and storage

9.1 包装 Packaging

磷酸铁锂电池组进行整体包装，以确保产品在搬运、运输、贮存中不受任何有害气体、化学污染、静电、潮湿和机械损伤。

The lithium iron phosphate battery pack is packaged as a whole to ensure that the product is protected from any harmful gases, chemical pollution, static electricity, humidity and mechanical damage during handling, transportation and storage.

9.2 运输 Transportation

电池搬运过程应注意以下方面：

The following aspects should be noted during battery transportation:

- (1) 应轻拿轻放，避免设备受剧烈震动；

It should be handled gently to avoid violent shocks to the equipment;

- (2) 禁止倒置、翻滚、摔、撞电池，避免破坏电池的外观；

Avoid damaging the appearance of the battery by inverting, tumbling, dropping or hitting it;

- (3) 电池应避免暴晒、雨淋，禁止直接将电池整体浸入水中；

Batteries should be protected from exposure to the sun and rain, and direct submersion of the whole battery in water is forbidden;

- (4) 禁止正负极短路；

Negative and positive short circuits are prohibited;

9.3 储存 Storage

- (1) 电池组的外接端子处于绝缘防护状态；

The external terminal of the battery pack is in an insulation protection state;

- (2) 存期超过 6 个月的电池组要相应进行充电，打开电池开关，指示灯点亮，当电量为 30%-50%时，以 0.2C 充电 1 小时；当电量为 30%及以下时，以 0.2C 充电 3 小时；

Battery packs that have been in storage for more than 6 months should be recharged accordingly by turning on the battery switch, with the indicator light up, and charging at 0.2C for 1 hour when the charge is 30%-50%, and at 0.2C for 3 hours when the charge is 30% or less;

- (3) 电池不要在 60°C 高温下长期存储或放置，否则会引起功能衰退、寿命减小；

Do not store or leave batteries at 60°C for long periods of time as this may cause deterioration of function and reduced life;

10. 质保及其他 Warranties and others

- (1) 产品在质保期内，保质期：5 年；

The product is within the warranty period, Guarantee period of quality: 10 years;

- (2) 客户需遵从产品的维护使用说明进行使用，需经授权专业人员安装、调试、维护；

The customer is required to follow the instructions for the maintenance and use of the product, which is subject to installation, commissioning and maintenance by authorised professionals;

(3)客户必须通过伟创源或者伟创源授权的经销商处购买此产品；

Customers must purchase this product through Kexin or Kexin UP authorized distributors;

(4)产品在未被授权的情况下不得私自打开、修改、加工或维护；

The product shall not be opened, modified, processed or maintained without authorization;

(5)不得修改产品的记录数据；

Do not modify the recorded data of the product;

(6)客户若需要将电池用于超出文件规定以外的设备，或在文件规定以外的使用条件下使用电池，应事先联系伟创源，因为需要进行特定的实验测试以验证电池在该使用条件下的性能及安全性；

Customers who need to use batteries in equipment other than that specified in the documentation, or to use batteries under conditions of use other than those specified in the documentation, should contact Kexin UP in advance, as specific laboratory tests are required to verify the performance and safety of the batteries under those conditions of use;

(7)对于在超出文件规定以外的条件下使用电池而造成的任何意外事故，伟创源概不负责；

Kexin UP is not responsible for any accidents caused by the use of batteries under conditions other than those specified in the documentation;

(8)任何本说明书中未提及的事项，须经双方协商确定；

Any matter not mentioned in this specification shall be determined by negotiation between the parties;

11. 风险警告 Risk Warning

警告 Warning

电池存在潜在的危險，在操作和维护时必须采取适当的防护措施！不正确地滥用测试实验，可能导致严重的人身伤害和财产损失！必须使用正确的工具和防护装备操作电池。

Batteries are potentially dangerous and must be operated and maintained with appropriate precautions! Improper misuse of test experiments can lead to serious personal injury and property damage! Batteries must be handled with the correct tools and protective equipment.

电池的维护必须由具有电池专业知识并经过安全培训的人士执行。不遵守上述警告可能造成多种灾难。

Battery maintenance must be carried out by persons with specialist knowledge of batteries and who have received safety training. Failure to comply with the above warnings could result in a number of disasters.